

Building connections that last™



# Snubbers

## Engineered Pipe Supports



**ANVILEPS**  
An ASC Engineered Solution

NUCLEAR RENEWABLE ENERGY COAL & NATURAL GAS MARINE  
DEFENSE PETRO-CHEMICAL NUCLEAR RENEWABLE ENERGY COAL  
& NATURAL GAS MARINE DEFENSE PETRO-CHEMICAL NUCLEAR  
RENEWABLE ENERGY COAL & NATURAL GAS MARINE DEFENSE  
PETRO-CHEMICAL NUCLEAR RENEWABLE ENERGY COAL & NAT-  
URAL GAS MARINE DEFENSE PETRO-CHEMICAL NUCLEAR RENEW-  
ABLE ENERGY COAL & NATURAL GAS MARINE DEFENSE PETRO-

# anvil snubbers

impeccable performance for critical applications

Anvil snubbers are velocity sensitive restraints for minimizing the movement of critical equipment and piping that if subjected to dynamic movements may cause catastrophic failure. They are the seat belts of the piping system, providing controlled restraint during seismic and dynamic events, while allowing normal thermal movement.

Our snubbers come in two different configurations as the Fig 200 and Fig 3306 and are available with a wide range of strokes, lockup velocities, bleed rates and finishes. They are also available for use in low temperature environments (down to -50° F). Our standard Fig 200's have integral external valves and reservoir. The Fig 3306 is our second generation snubber with upgraded seals, internal valves and reservoir, and has been designed as a drop in replacement for equivalent PSA mechanical snubbers. Fig 200's are available with both optional control valves and optional reservoir types – polycarbonate, metal, pressurized or remote. The optional control valves can be field adjustable or temperature compensating to minimize the effects of temperature on lockup and bleed.

Snubber fluid for nuclear applications is Anvil SF-N. SF-N is the brand name for dimethyldiphenylpolysiloxane that has come through our quality system, and has historically been known as SF-1154. It is fully mixable with SF-1154 and has the same excellent radiation resistant qualities (SF-1154 can be provided upon request). Commercial fluid is provided as polydimethylsiloxane and is not recommended for use in nuclear facilities.

The Fig. 3306 and Fig. 200 with temperature compensating valves and pressurized reservoir (Configuration A) are both qualified for continuous operating temperature of 157° F for 25 years with a radiation exposure no greater than  $2 \times 10^8$  rads. Polycarbonate reservoirs are not recommended for temperatures above 200° F.

Anvil has provided snubbers with load ratings up to 1.9 million pounds as well as strokes greater than 20". With our superior engineering expertise, Anvil can create a snubber solution to meet your load rating needs.

## a history of firsts

Anvil's history stretches back to the mid 1800's, when a company named Grinnell® began providing the finest quality pipe hangers and hardware. Recognized as a world leader in the field of pipe support and restraint design, Anvil has been:

The first Nuclear pipe support company to qualify as an ASME Material Supplier.

The first in the industry to receive the ASME NPT Stamp.

The first in the industry to receive the ASME NS certificate of accreditation.

The first to develop a LCDS Package for ASME NF qualified supports.

The first Hydraulic snubbers to meet new ASME QME/QDR requirements.

Anvil International has been a supplier of hydraulic snubbers since the inception of the commercial nuclear power industry in the 1960's. Our snubbers are used in safety related functions in nuclear facilities around the world, as well as critical application in the natural gas, coal and petro-chemical industries. Our high quality hydraulic snubbers are wholly manufactured in America at our Engineered Pipe Support (EPS) division in North Kingstown, RI.

*When it comes to insuring the safe operation of your piping system and your facility, choose American quality, choose the industry leader, choose Anvil International.*



Fig. 200  
 Fig. C-200  
 Fig. 201  
 Fig. C-201  
 With Extension Piece

**Size Range:**

Seven standard sizes with cylinder bores of 1 1/2" to 8" and with normal load ratings from 3,000 pounds to 128,000 pounds. All are available with 5", 10", 15", or 20" strokes except the 1 1/2" size which is offered with 5" and 10" strokes only. Snubbers are available with integral or remote reservoirs.

**Finish:**

Fig. 200/201 painted with semi gloss primer.  
 Fig. C-200/C-201 corrosion resistant; painted with carbo zinc.

**Service:**

For use on piping systems or equipment when unrestrained thermal movement must be allowed, but which must be restrained during impulsive or cyclic disturbance. The unit is not effective against low amplitude, high frequency movement. Use with standard settings to prevent destructive response to earthquakes, flow transients or wind load. Special settings are available to absorb the continuous thrust resulting from safety valve blow-off or pipe rupture.

**Standard settings:**

Locking (activation) velocity 8 +/- 2 in/min. Bleed rate (post activation) at normal rated load 4 +/- 1 in/min. (Special settings are available).

The valves are calibrated at the factory within the tolerances indicated at room temperature. Locking velocity and bleed rate will vary with temperature. Testing has indicated that there is little effect of these changes on dynamic operation.

**Features:**

- Choice of valve type
  - Adjustable – permits field adjustments
  - Temperature compensating – minimizes the effects of temperature on lockup and bleed
- Choice of reservoir type
  - Transparent – continuous operation at 200° F with brief transients to 250° F
  - Metal or pressurized metal – allows brief transients to 340° F
  - Pressurized – eliminates the concern of reservoir orientation relative to valve and cylinder – minimizes internal contamination
  - Remote
- Factory calibrated valves
- Rapid, positive valve closure
- Special design minimizes the "lost motion" which results from the shifting and seating of piston seals
- Unlocked resisting force is less than 1% of rated load
- Stable, non-flammable, long life hydraulic fluid made highly visible for ease of inspection
- Self-aligning bushings permit ±5° misalignment or angular motion. Bushings are coated with a dry lubricant.
- Choice of coating (paint, primer, carbo zinc, epoxy, plating or other)

**Upgrade Kits:**

Kits are available to upgrade existing snubbers to temperature compensating valves and/or pressurized reservoir.

LOADS (LBS)	
Cylinder Size (in)	Max Load *
1 1/2 (5" stroke)	3,000
1 1/2 (10" stroke)	1,250
2 1/2 (5", 10", 15" stroke)	12,500
2 1/2 (20" stroke)	10,500
3 1/4	21,000
4	32,000
5	50,000
6	72,000
8	128,000

\* Loads must not be applied outside a 10° included angle cone of action to the pipe clamp axis without special authorization.

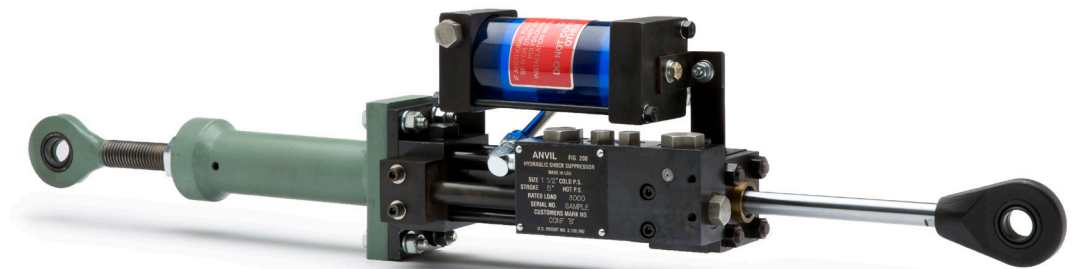
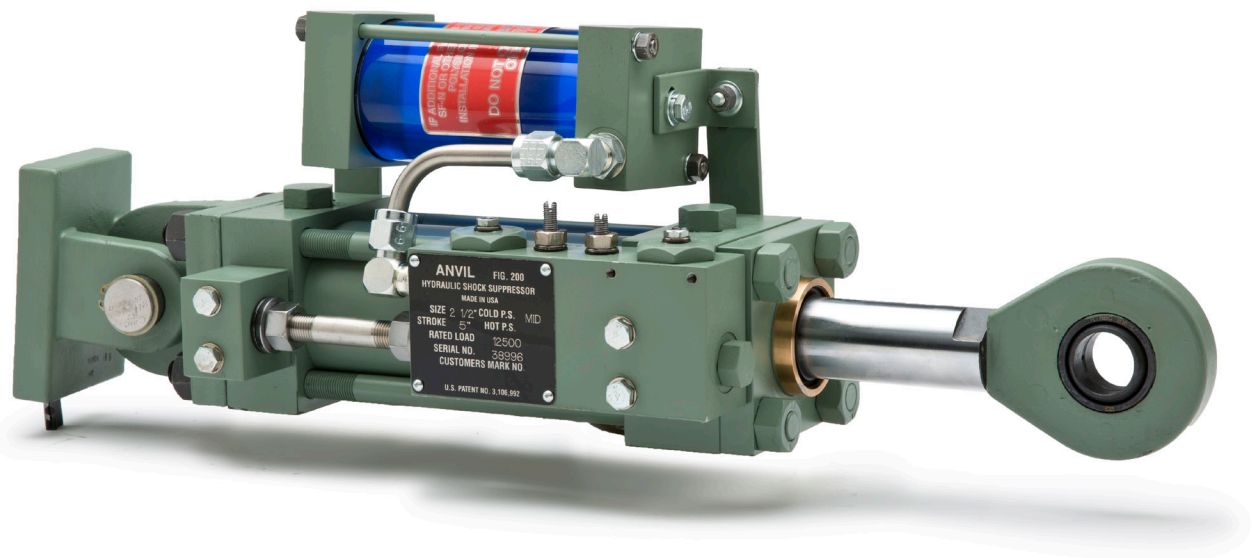

Fig. 200  
 Fig. C-200  
 Fig. 201  
 Fig. C-201  
 With Extension Piece

Non-Safety Related  
 (Commercial)

**How to size:**

(1) Cylinder size: Use table on page 9 to select cylinder bore size large enough to restrain expected load.

(2) Stroke: Define expected movement of the pivot joining the suppressor with the equipment to be protected (cold to hot plus any abnormal movements). Determine maximum and minimum distances between this curve and the fixed pivot pin of the snubber. The minimum recommended stroke is 20% greater than the difference between these lengths.

Note: If erected position at the snubber's location on the equipment is outside of the range of normal cold-to-hot movement (e.g. cold pull of pipe), the snubber should not be installed until after the equipment is in its cold position. This eliminates the need of providing for the extra travel in the snubber's stroke. For 2 1/2" through 8" snubbers, standard strokes are 5", 10", 15", and 20". For the 1 1/2" snubber, 5" and 10" are the only standard strokes.

(3) Installed piston setting: As indicated previously, the snubber should be installed at its cold piston position if possible. From the installed position, take extension (outward movement) of the piston rod as positive (+) and retraction as negative (-).

(4) Installed piston position

$$\left( \frac{\text{Stroke} - (\text{Algebraic Sum of Movements})}{2} \right)$$

To aid in measuring the piston position, we have shown a dimension, "Z". This dimension represents the distance between the cylinder head and the end of the rod when the rod is fully retracted. Whenever specifying the position at which the piston rod is to be set, the total dimension from the cylinder head to the end of the rod should be given. Thus, Piston Setting = Piston Position + Z.

(5) Assembly length: Determine the installed "C" dimension by adding the installed piston position (not setting) to C minimum. Lay in take out dimensions E and/or B, and find required pin-to-pin snubber length. If a pin-to-pin length adjustment is desired, use Fig. 201. Calculate the required "W" dimension by subtracting (C installed + F) from the required pin-to-pin length. If this is less than W minimum, only a Fig. 200 can be used, and one of the attachments will have to be moved or shimmed to suit. If a Fig. 200 is to be used, make sure that the required pin-to-pin length is at least as great as (C installed + B). If neither a Fig. 200 nor a Fig. 201 can be accommodated, and the installation cannot be modified, consult your Anvil representative about designing a special or modified unit.

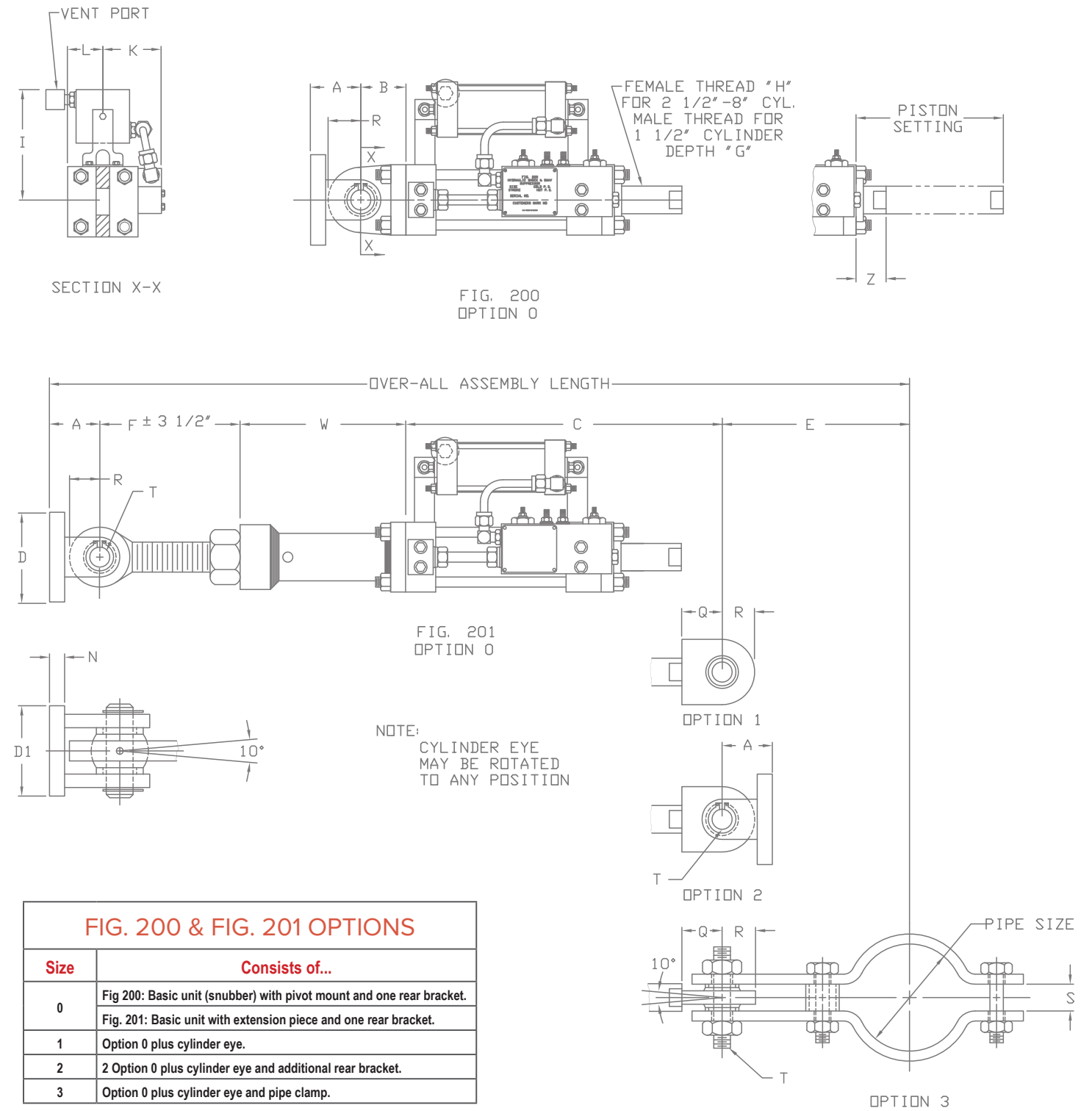

Fig. 200

Fig. 201

Non-Safety Related  
(Commercial)

FIG 200, 201: WEIGHT (LBS) • DIMENSIONS (IN)																									
Cylinder		Fig. 200 Wt.	A	B	C			D	D1	F	G	H	I			K	L	N	Q	R	S	T	W		Z
Bore	Stroke				Min	Mid	Max						Metal Res.	Trans. Res.	Press. Res.								Min	Max	
1½	5	45	2½	1½	13¾	15½	18½	2	2¾	6	¾	¾-18	5¾	4¼	4¾	2¾	2¼	¾	2½	1½	1	¾	9½	75½	¾
	10	49			18¾	23¾	28½																	65½	
2½	5	75	2½	2¼	13¾	15½	18¾	2	2¾	7¾	¾	¾-14	6¼	5½	5¾	3¼	1¾	¾	2	1½	1¾	1	10¾	94¾	1
	10	81			18¾	23¾	28¾																	84¾	
	15	87			23¾	30¾	38¾																	74¾	
	20	93			28¾	38¾	48¾																	64¾	
3¼	5	121	3	3	14¾	17¾	19¾	3	3¾	7½	1½	1½-12	6¾	5¾	6¾	3¾	2¼	¾	2½	2½	1½	1¼	10½	92	1½
	10	132			19¾	24¾	29¾																	82	
	15	146			24¾	32¾	39¾																	72	
	20	156			29¾	39¾	49¾																	62	
4	5	177	4	3¾	16¾	18¾	21¾	6½	4¼	9½	1½	1½-12	7½	6	7¼	4	2½	1¼	3¾	2½	2	1½	11½	89¾	1½
	10	189			21¾	26¾	31¾																	79¾	
	15	206			26¾	33¾	41¾																	69¾	
	20	223			31¾	41¾	51¾																	59¾	
5	5	235	5	4½	18	20½	23	7½	5¾	10¾	1½	1½-12	8½	7	9¾	4¾	3¼	1¾	4	3½	2¾	1¾	12	86¾	1½
	10	256			23	28	33																	76¾	
	15	277			28	35½	43																	66¾	
	20	298			33	43	53																	56¾	
6	5	292	5¾	5½	19¾	22¼	24¾	9½	6¼	11¾	2¼	2¼-12	9¾	7¾	10½	5¼	3¾	2	4¾	3½	2¾	2	13¾	83¾	1¾
	10	320			24¾	29¾	34¾																	73¾	
	15	348			29¾	37¼	44¾																	63¾	
	20	375			34¾	44¾	54¾																	53¾	
8	5	515	7¼	6	23½	26	28½	14	8¾	14½	4	3-12	12½	N/A	13¾	8½	4¾	2¼	6¾	4¾	—	2½	14½	75½	2¼
	10	575			28½	33½	38½																	65½	
	15	640			33½	41	48½																	55½	
	20	705			38½	48½	58½																	45½	

\* F is adjustable for +/- 3½" for non-safety related applications.

FIG 200, 201: WEIGHT (LBS) • DIMENSIONS (IN)													
Pipe Size	E-Take Out						Clamp Stock Size						
	Cylinder Bore						Cylinder Bore						
	1½	2½	3¼	4	5	6	1½	2½	3¼	4	5	6	
2	6	6¾	—	—	—	—	¾ x 1¾	½ x 2½	—	—	—	—	
2½	7	7	—	—	—	—	¾ x 1¾	½ x 2½	—	—	—	—	
3	7	7	—	—	—	—	¾ x 1¾	½ x 2½	—	—	—	—	
3½	7	7	—	—	—	—	¾ x 1¾	½ x 2½	—	—	—	—	
4	7¼	7¼	—	—	—	—	½ x 1½	¾ x 2½	—	—	—	—	
5	7¾	7¾	9¾	10	—	—	½ x 1½	¾ x 2½	¾ x 3	¾ x 5	—	—	
6	8¾	8¾	10	10	11¾	—	½ x 2	¾ x 3	¾ x 4	¾ x 5	1 x 5	—	
8	9¾	9¾	11¼	11¼	12¾	—	½ x 2½	¾ x 3	¾ x 5	1 x 5	1 x 6	—	
10	10½	10½	12¾	12¾	14¼	—	¾ x 2½	¾ x 4	¾ x 6	1 x 5	1 x 7	—	
12	11¾	11¾	13¾	13¾	15¾	—	¾ x 2½	¾ x 5	1 x 5	1 x 6	1 x 7	—	
14	12¾	12¾	14½	14½	16	—	¾ x 2½	¾ x 5	1 x 5	1 x 7	1¼ x 6	—	
16	13¾	13¾	15¼	15¼	17¾	—	¾ x 3	¾ x 6	1 x 5	1 x 7	1¼ x 6	—	
18	14¾	14¾	16¾	16¾	18¼	—	¾ x 3	1 x 5	1 x 6	1 x 7	1¼ x 7	—	
20	15¾	15¾	17¾	17¾	19¼	19¼	¾ x 3	1 x 5	1 x 7	1¼ x 6	1¼ x 8	1½ x 8	
24	18¾	18¾	19¾	19¾	21¾	21¾	¾ x 4	1 x 5	1 x 7	1¼ x 6	1¼ x 9	1½ x 9	
30	21¼	21¼	23	23	25	25	¾ x 4	1 x 6	1¼ x 6	1¼ x 8	1½ x 8	1¾ x 10	
36	24	24	26½	26½	28¾	28¾	¾ x 5	1 x 7	1¼ x 6	1¼ x 9	1½ x 10	1¾ x 10	

# Fig. 200N

# Fig. 201N

Nuclear Safety  
Related Applications

FIG 200N/201N LOAD RATINGS (IN)			
Bore Size	Design & Levels A&B	Level C	Level D
1½*	3000/1250	3600/1650	4000/1950
2½	10350	13750	19100
3¼	17600	23450	30800
4	27300	37300	45000
5	45500	62000	75000
6	68200	92900	112600
8	110000	132000	165000

\* Lesser Load rating is for 10" stroke.

FIG 200N, 201N MAXIMUM PIN TO PIN LENGTHS (IN)				
Snubber Size		Design & Levels A&B	Level C	Level D
1½	- 5	100	100	95*
	- 10	100	100	95*
2½	- 5	120	120	105*
	- 10	120	120	100*
	- 15	115	115	85*
	- 20	100	90*	—
3¼	- 5	120	120	115*
	- 10	120	120	115*
	- 15	120	120	110*
	- 20	120	120	95*
4	- 5	120	120	120
	- 10	120	120	120
	- 15	120	120	120
	- 20	120	120	120
5	- 5	120	120	120
	- 10	120	120	120
	- 15	120	120	120
	- 20	120	120	120
6	- 5	120	120	120
	- 10	120	120	120
	- 15	120	120	120
	- 20	120	120	120
8	- 5	120	120	120
	- 10	120	120	120
	- 15	120	120	120
	- 20	120	120	120

\* The reduced pin to pin will reduce the Wmax on Page 12.

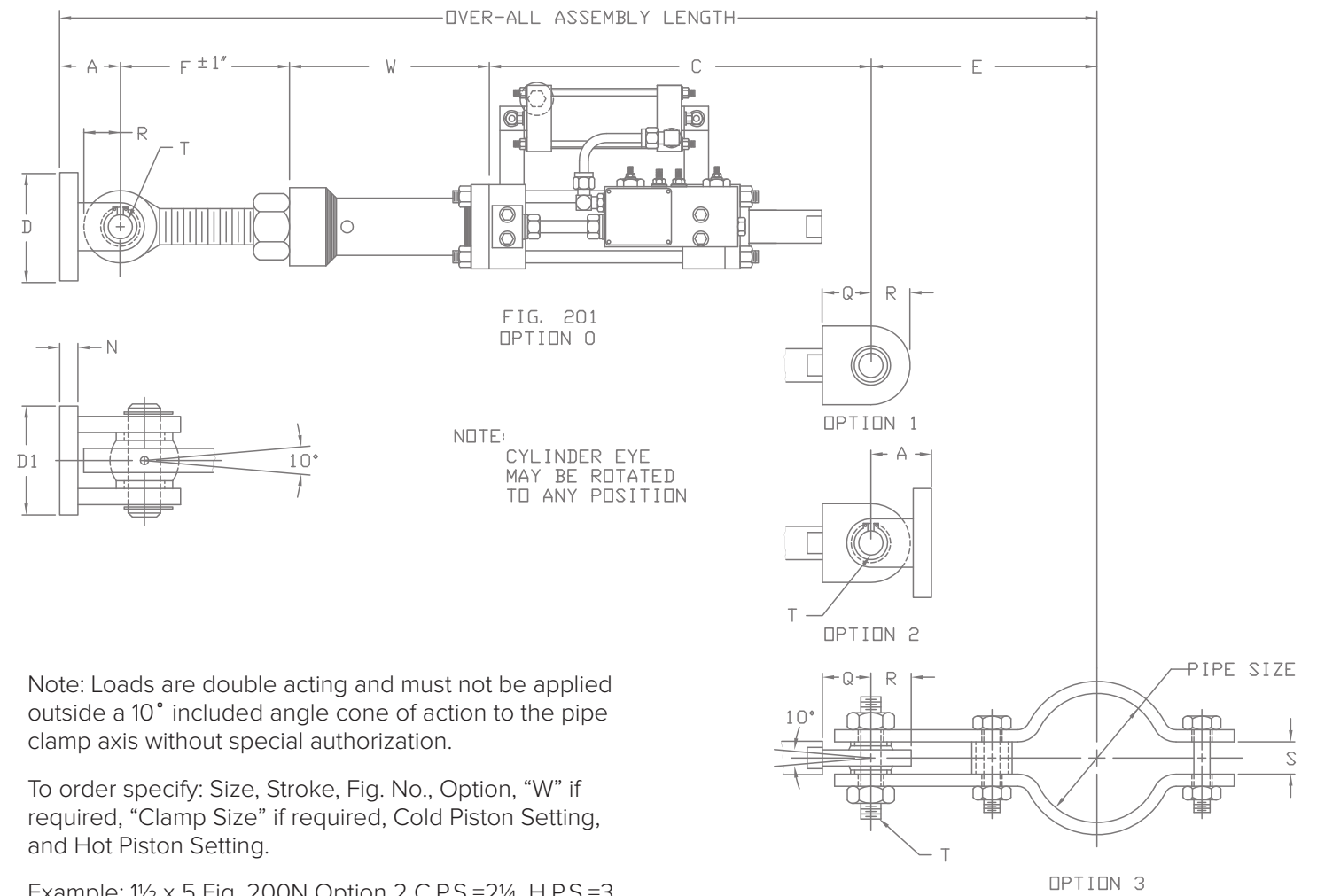
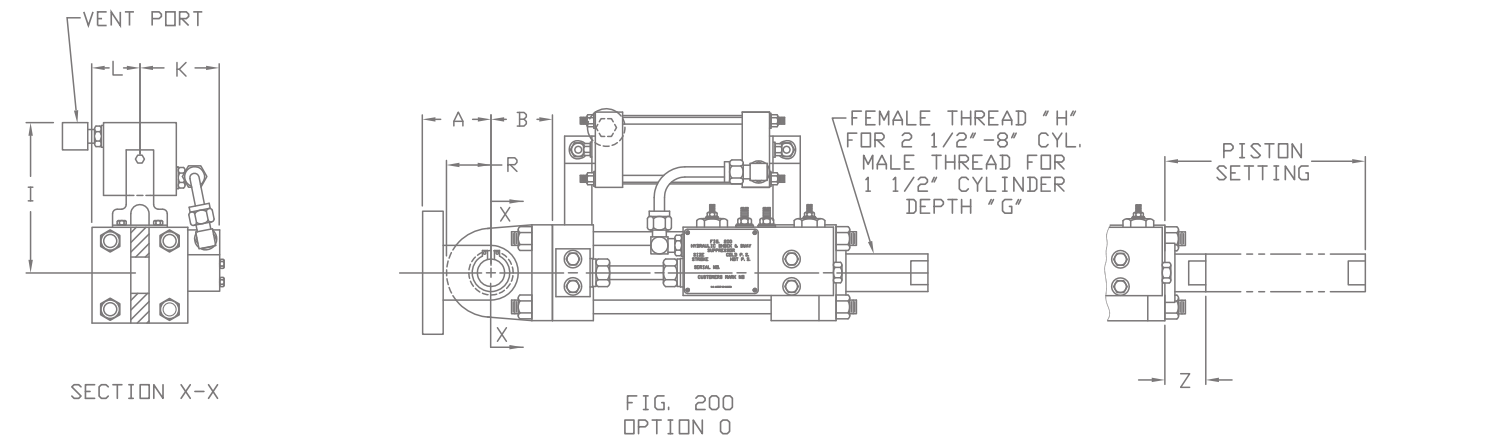

Note: Loads are double acting and must not be applied outside a 10° included angle cone of action to the pipe clamp axis without special authorization.

To order specify: Size, Stroke, Fig. No., Option, "W" if required, "Clamp Size" if required, Cold Piston Setting, and Hot Piston Setting.

Example: 1½ x 5 Fig. 200N Option 2 C.P.S.=2¼, H.P.S.=3

Fig. 200N

Fig. 201N

Nuclear Safety  
Related Applications

FIG 200, 201: WEIGHT (LBS) • DIMENSIONS (IN)

Cylinder		A	B	C			D	D1	F	G	H	I	K	Wgt. Ea. Fig 200N Lbs	L	M	N	Q	R Max	S	T	W		Z
Bore	Stroke			Min	Mid	Max																Min	Max	
1½	5	2.00	1.62	13.12	15.62	18.12	3.25	2.00	3.50	.75	¾-18	5.56	2.75	45	1.25	1.94	.50	2.12	1.12	1.00	.747 .749	4.50	78.38*	.62
	10			18.12	23.12	28.12																	68.38*	
2½	5	2.50	2.25	13.38	15.88	18.38	4.50	3.00	4.69	.88	¾-14	6.25	3.25	75	1.75	2.38	.75	2.00	1.62	1.38	.997 .999	5.38	96.93*	1.00
	10			18.38	23.38	28.38																	86.93*	
	15			23.38	30.88	38.38																	71.93*	
	20			28.38	38.38	48.38																	46.93*	
¾	5	3.25	3.00	14.88	17.38	19.88	5.38	3.56	5.44	1.12	1½-12	6.88	3.75	121	2.25	2.88	1.00	2.50	2.06	1.69	1.247 1.249	5.50	94.68*	1.12
	10			19.88	24.88	29.88								84.68*										
	15			24.88	32.38	39.88								74.68*										
	20			29.88	39.88	49.88								64.68*										
4	5	4.00	3.75	16.12	18.62	21.12	6.12	4.25	6.81	1.50	1½-12	7.12	4.00	177	2.50	3.50	1.25	3.38	2.50	2.00	1.499 1.497	6.50	92.06	1.12
	10			21.12	26.12	31.12								82.06										
	15			26.12	33.62	41.12								72.06										
	20			31.12	41.12	51.12								62.06										
5	5	5.00	4.50	18.00	20.50	23.00	7.88	5.38	7.69	1.88	1¾-12	8.50	4.75	235	3.25	4.50	1.75	4.00	3.06	2.38	1.747 1.749	7.00	89.31	1.88
	10			23.00	28.00	33.00								79.31										
	15			28.00	35.50	43.00								69.31										
	20			33.00	43.00	53.00								59.31										
6	5	5.75	5.50	19.75	22.25	24.75	9.12	6.25	8.81	2.25	2¼-12	9.06	5.25	292	3.75	4.50	2.00	4.62	3.50	2.75	1.997 1.999	8.38	86.44	1.75
	10			24.75	29.75	34.75								76.44										
	15			29.75	37.25	44.75								66.44										
	20			34.75	44.75	54.75								56.44										
8	5	7.25	6.00	23.50	26.00	28.50	14.00	8.75	12.00	4.00	3-12	12.50	8.50	515	4.88	6.62	2.25	6.75	4.75	3.38	2.497 2.499	9.50	79.50	2.25
	10			28.50	33.50	38.50								69.50										
	15			33.50	41.00	48.50								59.50										
	20			38.50	48.50	58.50								49.50										

E - TAKE OUT

*Pipe Size	Cylinder Bore					
	1½	2½	¾	4	5	6
2	6	6¾	—	—	—	—
2½	7	7	—	—	—	—
3	7	7	—	—	—	—
¾	7	7	—	—	—	—
4	7¼	7¼	—	—	—	—
5	7¾	7¾	9¾	—	—	—
6	8¾	8¾	10	10	11¾	—
8	9¾	9¾	11¼	11¼	12¾	—
10	10½	10½	12¾	12¾	14¼	—
12	11¾	11¾	13¾	13¾	15¾	—
14	12¾	12¾	14½	14½	16	—
16	13¾	13¾	15¼	15¼	17¾	—
18	14¾	14¾	16¾	16¾	18¼	—
20	15¾	15¾	17¾	17¾	19¼	19¼
24	18¾	18¾	19¾	19¾	21¼	21¼
30	21¼	21¼	23	23	25	25
36	24	24	26½	26½	28¾	28¾

G - STOCK SIZE

*Pipe Size	Cylinder Bore					
	1½	2½	¾	4	5	6
2	¾ X 1¾	½ X 2½	—	—	—	—
2½	¾ X 1¾	½ X 2½	—	—	—	—
3	¾ X 1¾	½ X 2½	—	—	—	—
¾	¾ X 1¾	½ X 2½	—	—	—	—
4	½ X 1½	¾ X 2½	—	—	—	—
5	½ X 1½	¾ X 2½	¾ X 3	—	—	—
6	½ X 2	¾ X 3	¾ X 4	¾ X 5	1 X 5	—
8	½ X 2½	¾ X 3	¾ X 5	1 X 5	1 X 6	—
10	¾ X 2½	¾ X 4	¾ X 6	1 X 5	1 X 7	—
12	¾ X 2½	¾ X 5	1 X 5	1 X 6	1 X 7	—
14	¾ X 2½	¾ X 5	1 X 5	1 X 7	1¼ X 6	—
16	¾ X 3	¾ X 6	1 X 5	1 X 7	1¼ X 6	—
18	¾ X 3	1 X 5	1 X 6	1 X 7	1¼ X 7	—
20	¾ X 3	1 X 5	1 X 7	1¼ X 6	1¼ X 8	1½ X 8
24	¾ X 4	1 X 5	1 X 7	1¼ X 6	1¼ X 9	1½ X 9
30	¾ X 4	1 X 6	1¼ X 6	1¼ X 8	1½ X 8	1¾ X 10
36	¾ X 5	1 X 7	1¼ X 6	1¼ X 9	1½ X 10	1¾ X 10

\* Intermediate sizes between 20 and 36 are available and will have the take out and stock of the next larger size.

**Fig. 3306  
3306N**

**Fig. 3307  
3307N**  
With Extension Piece

Anvil's Fig. 3306/3306N Hydraulic Snubbers are designed as a direct replacement for the Pacific Scientific PSA-1/4 through PSA-100 mechanical snubbers. Exact load ratings, pin sizes, stroke lengths, pin to pin and cross sectional dimensions ensure that the 3306/3306N is a drop in replacement. In addition, the pins, clamps, pivot mounts, extension pieces and rear brackets used on the PSA snubbers are also compatible.

The 3306N is a second generation snubber that incorporates upgraded yet reliable T-seals, internal pressurized reservoir, and temperature compensating valves. The design has been tested to the most exacting ASME QME/QDR standard for qualification for use in nuclear facilities, and offers reliability in within a compact envelope.

For new installations, the 3306 is available to ASME Section III Subsection NF and is available with a complete line of pipe clamps and rear brackets. The following coatings can be ordered standard for the attachments: paint, primer, carbo zinc, epoxy, and plating. The snubber unit is finished with a corrosion resistant ferritic nitrocarburizing case-hardening treatment. For applications in extremely corrosive environments, such as high humidity or a marine type environment, please inquire about corrosion resistant units.



**Design Features:**

- Drop-in replacement for PSA mechanical snubbers with no interference. PSA pivot mounts, transition tubes, clamps, and rear brackets can be reused at your discretion.
- Functional and Dynamic Qualification: Qualification is to the proposed ASME QME/QDR standard for dynamic restraints.
- A pre-service functional test per ASME O&M code subsection ISTD is performed on every production snubber
- Factory calibrated, tamper-proof, temperature compensating valves minimized the effects of temperatures on lock up and bleed and eliminate the need for a narrow range of functional test acceptance criteria.
- The bleed valve incorporates a multi-orifice design with proven resistance to clogging.

- The pressurized reservoir insures positive fluid pressure regardless of snubber orientation.
- Continuous operation at 157° F with brief transients to 350°F.
- Unlocked resisting force is less than 17 ½ pounds for sizes ¼ and ½ and less than 2% of rated load for larger sizes.
- Special design minimizes the “lost motion” which results from the shifting and seating of piston seals.
- Stable non-flammable, long life hydraulic fluid can be visually inspected and the exact fluid level can be measured.
- The dry lubricated, self-aligning bushings permit ±5° misalignment of angular motion.
- All seals and fluid have a 25 year service life at 157°F.
- For Nuclear application, the 3306N/3307N utilizes seals and SF-N fluid which are radiation resistant to 2 x 10<sup>8</sup> rads.



**Size Range:**  
Available in eight standard sizes with load ratings from 350 to 120,000 pounds.

LOADS (LBS)		
Size	Stroke (in)	Max Load *
¼	4	350
½	2½	650
1	4, 8	1,500
3	5, 10	6,000
10	6, 12	15,000
35	6	50,000
100	6	120,000

\* Loads must not be applied outside a 10° included angle cone of action to the pipe clamp axis without special authorization.

**Finish:**  
Basic unit is corrosion resistant salt bath nitrided and non-reactive to Boron spray.

**Standard Settings:**  
Locking (activation) velocity 8 ± 2 in/min. Bleed rate (post activation) at normal rated load 4 ± 1 in/min. (Special settings are available.) The valves are calibrated at the factory within the tolerances indicated at room temperature. Locking velocity and bleed rate will vary with temperature. Testing has indicated that there is little effect of these changes on dynamic operation.

**Fig. 3306**  
**3306N**

**Fig. 3307**  
**3307N**  
With Extension Piece

**How to size:**

(1) Size: Use table on the previous page to select size large enough to restrain expected load.

(2) Stroke: Define expected movement of the pivot joining the snubber with the equipment to be protected (cold to hot plus any abnormal movements). Determine maximum and minimum distances between this curve and the fixed pivot pin of the snubber. The minimum recommended stroke is 20% greater than the difference between these lengths. Make sure that all normal movement of equipment will be accommodated without the snubber entering the last 1/4" (preferably 1/2") of the stroke at either end.

Note: If erected position at the snubber's location on the equipment is outside of the range of normal cold-to-hot movement (e.g cold pull of pipe), the snubber should not be installed until after the equipment is in its cold position. This eliminates the need of providing for the extra travel in the snubber's stroke.

(3) Piston position: To aid in measuring the piston position, we have shown a dimension, "Z". This dimension represents the distance between the cylinder head and the end of the rod when the rod is fully retracted. Whenever specifying the position at which the piston rod is to be set, the total dimension from the cylinder head to the end of the rod should be given. Thus, piston setting=piston position +Z.

(4) Assembly length: Determine the installed "C" dimension by adding the installed piston position (not setting) to C minimum. Lay in takeout dimensions E and/or B, and find required pin-to-pin snubber length. If a pin-to-pin length adjustment is desired, use Fig. 3307. Calculate the required "W" dimension by subtracting (C installed + F) from the required pin-to-pin length. If this is less than W minimum, only a Fig. 3306 can be used, and one of the attachments will have to be moved or shimmed to suit. If a Fig. 3306 is to be used, make sure that the required pin-to-pin length is at least as great as (C installed + B). If neither a Fig. 3306 nor a Fig. 3307 can be accommodated, and the installation cannot be modified, consult your Anvil representative about designing a special or modified unit.

(5) Installed piston setting: As indicated previously, the snubber should be installed at its cold piston position if possible. From the installed position, take extension (outward movement) of the piston rod as positive (+) and retraction as negative (-). Installed piston position =

$$\left( \frac{\text{Stroke} - (\text{Algebraic Sum of Movements})}{2} \right)$$

**Ordering: Specify**

- Fig. No.
- Size
- Stroke
- Load
- Cold and hot piston settings
- W dimension when specifying Fig. 3307
- Pipe clamp size when specifying option 3
- Attachment surface coating
- Option

**FIG. 3306 & 3307 OPTIONS**

Option	Consists of...
0	Fig 3306: Basic unit (snubber) with pivot mount and one rear bracket.
0	Fig. 3307: Basic unit with extension piece and one rear bracket.
1	Option 0 plus cylinder eye.
2	Option 0 plus cylinder eye and additional rear bracket.
3	Option 0 plus cylinder eye and pipe clamp.



Fig. 3306

Fig. 3307

With Extension Piece

Non-Safety Related  
(Commercial)

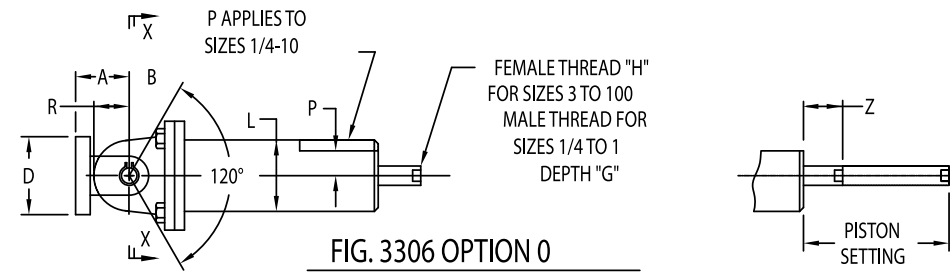

FIG. 3306 OPTION 0

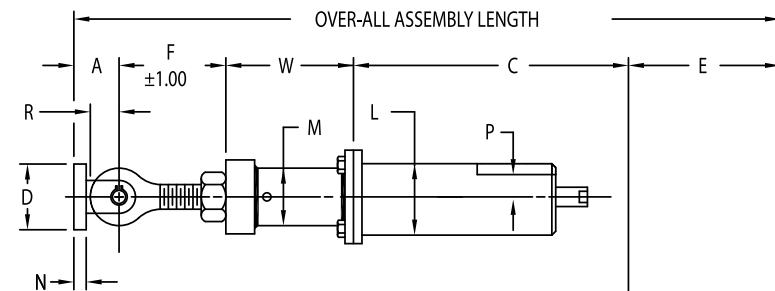
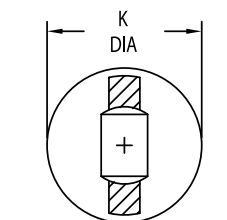
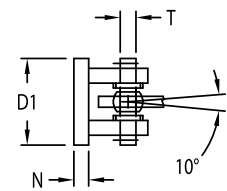
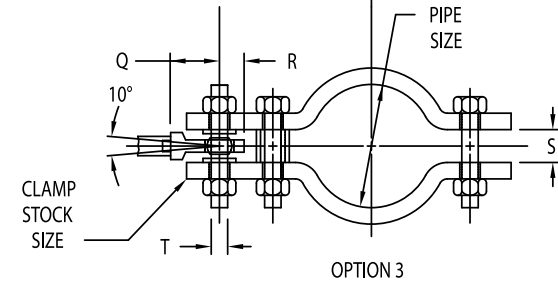
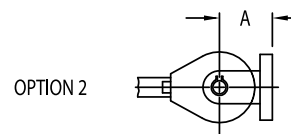
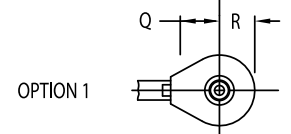

FIG. 3307 OPTION 0



SECTION X-X  
(BOLT PLATE SIZE 1/4-10)



NOTE:  
CYLINDER EYE  
MAY BE ROTATED  
TO ANY POSITION

FIG 3306, 3307 DIMENSIONS (IN)

Snubber Size	Stroke	A	B	C*			D	D1	F	G	H	K Dia	L Dia	M Dia	N	P	Q Ref	R Max	S	T Dia	W		Max Pin to Pin	W
				Min	Mid	Max															Min	Max		
1/4	4.00	1.00	1.19	9.0	11.00	13.0	2.00	1.25	2.94	0.38	3/8-16-2A	2.25	2.25	1.31	0.25	0.62	1.19	0.63	0.63	0.374 0.372	3.50	45.56	61.50	0.19
1/2	2.50			7.5	8.75	10.0															3.50	48.56		
1	4.00	1.62	1.56	11.0	13.00	15.0	4.00	1.75	3.00	0.38	3/8-16-2A	3.25	2.38	1.31	0.38	0.69	2.00	1.00	1.00	0.499 0.497	3.87	43.50	61.50	0.13
	8.00			15.5	19.50	23.5															N/A	N/A		
3	5.00	2.12	2.62	14.0	16.50	19.0	5.00	3.62	4.50	0.75	3/8-18-2B	4.62	4.62	2.38	0.50	1.44	2.12	1.38	1.38	0.749 0.747	4.44	37.50	61.00	1.25
	10.00			20.0	25.00	30.0															N/A	N/A		
10	6.00	3.00	4.06	16.1	19.10	22.1	7.00	4.00	5.12	1.00	7/8-14-2B	5.75	5.75	2.88	1.00	1.62	2.00	1.62	1.38	0.999 0.997	5.19	44.50	71.72	2.10
	12.00			23.1	29.10	35.1															N/A	N/A		
35	6.00	4.62	3.00	24.0	27.00	30.0	9.75	6.50	7.75	1.88	1 1/8-12-2B	—	6.00	4.50	1.25	—	3.00	2.79	2.00	1.499 1.497	5.25	79.75	117.50	1.48
100	6.00	7.25	3.80	29.0	32.00	35.0	14.0	8.75	8.31	3.00	3-12-2B	—	10.00	5.56	2.00	—	3.80	3.44	—	—	6.50	74.18	117.50	3.38

\* Adapters are available to match existing pin-to-pins.

FIG 3306, 3307 DIMENSIONS (IN)

*Pipe Size	E-Take Out					Clamp Stock Size				
	Snubber Size					Snubber Size				
	1/4 & 1/2	1	3	10	35	1/4 & 1/2	1	3	10	35
3/4	2 1/16	—	—	—	—	3/16 x 1	—	—	—	—
1	2 5/16	—	—	—	—	3/16 x 1	—	—	—	—
1 1/4	2 11/16	—	—	—	—	3/16 x 1	—	—	—	—
1 1/2	4 1/8	—	—	—	—	1/4 x 1 1/4	—	—	—	—
2	5 1/8	—	—	—	—	1/4 x 1 1/4	—	—	—	—
2 1/2	5 3/8	7	7	7	—	1/4 x 1 1/4	3/8 x 1 3/4	1/2 x 2 1/2	5/8 x 2 1/2	—
3	5 11/16	7	7	8 1/8	—	1/4 x 1 1/4	3/8 x 1 3/4	1/2 x 2 1/2	5/8 x 2 1/2	—
3 1/2	6 1/16	7	7	8 1/8	—	1/4 x 1 1/4	3/8 x 1 3/4	1/2 x 2 1/2	5/8 x 2 1/2	—
4	6 1/2	7 1/4	7 1/4	8 3/8	—	5/16 x 2	1/2 x 1 1/2	5/8 x 2 1/2	5/8 x 2 1/2	—
5	7 3/4	7 3/4	7 3/4	9 1/8	—	5/16 x 2	1/2 x 1 1/2	5/8 x 2 1/2	3/4 x 3	—
6	8 3/8	8 3/8	8 3/8	10	—	5/16 x 2	1/2 x 2	5/8 x 3	3/4 x 4	—
8	9 3/8	9 3/8	9 3/8	11 1/4	12 3/8	5/16 x 2	1/2 x 2 1/2	3/4 x 3	3/4 x 5	1 x 7
10	10 1/2	10 1/2	10 1/2	12 3/4	14 1/4	5/16 x 2	5/8 x 2 1/2	3/4 x 4	3/4 x 6	1 1/4 x 6
12	—	11 1/8	11 1/8	13 3/8	15 3/8	—	5/8 x 2 1/2	3/4 x 5	1 x 5	1 1/4 x 6
14	—	12 3/8	12 3/8	14 1/2	16	—	5/8 x 2 1/2	3/4 x 5	1 x 5	1 1/4 x 7
16	—	13 3/8	13 3/8	15 1/4	17 1/8	—	5/8 x 3	3/4 x 5	1 x 5	1 1/4 x 8
18	—	14 3/8	14 3/8	16 3/8	18 1/4	—	3/4 x 3	3/4 x 5	1 x 6	1 1/4 x 9
20	—	15 3/8	15 3/8	17 3/4	19 1/4	—	3/4 x 3	3/4 x 5	1 x 7	1 1/2 x 8
24	—	18 3/8	18 3/8	19 3/8	21 1/4	—	3/4 x 4	3/4 x 5	1 x 7	1 1/2 x 9
30	—	21 1/4	21 1/4	23	25	—	3/4 x 4	3/4 x 6	1 x 7	1 1/2 x 10
36	—	24	24	26 1/2	28 1/8	—	3/4 x 5	3/4 x 7	1 x 7	1 1/2 x 10

\* Intermediate sizes between 20 and 36 are available and will have the take out and stock of the next larger size.  
Note: "E" Dimensions are for carbon steel clamps only, with maximum insulation of 4" and temperature of 650°.

Fig. 3306N

Fig. 3307N

Nuclear Safety  
Related Applications

FIG. 3306N/3307N Load Ratings (LBS)				
Size	Stroke	Design & Levels A&B	Level C	Level D
¼	4	350	512	590
½	2½	650	865	1040
1	4	1500	2067	2300
1	8	1487	1978	2200
3	5	6000	8610	11520
3	10	6000	8610	11520
10	6	15000	20100	23600
10	12	14400	19152	22032
35	6	50000	70350	91000
100	6	120000	160000	180000

Note: Clamps and Rear Brackets are per the corresponding Fig. 3306 Snubber. See Page 18.

Sizes 1/4, 1/2, 1, 3 & 10

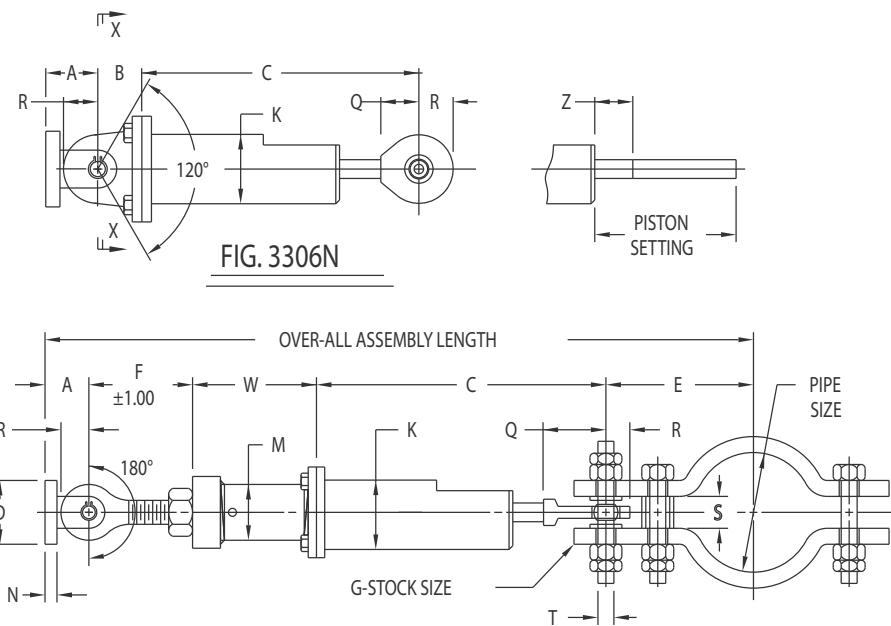
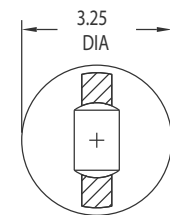
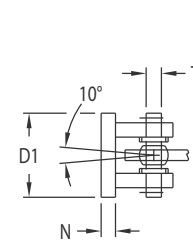

FIG. 3307N



SECTION X-X  
(BOLT PLATE SIZE 1 ONLY)

Sizes 35 & 100

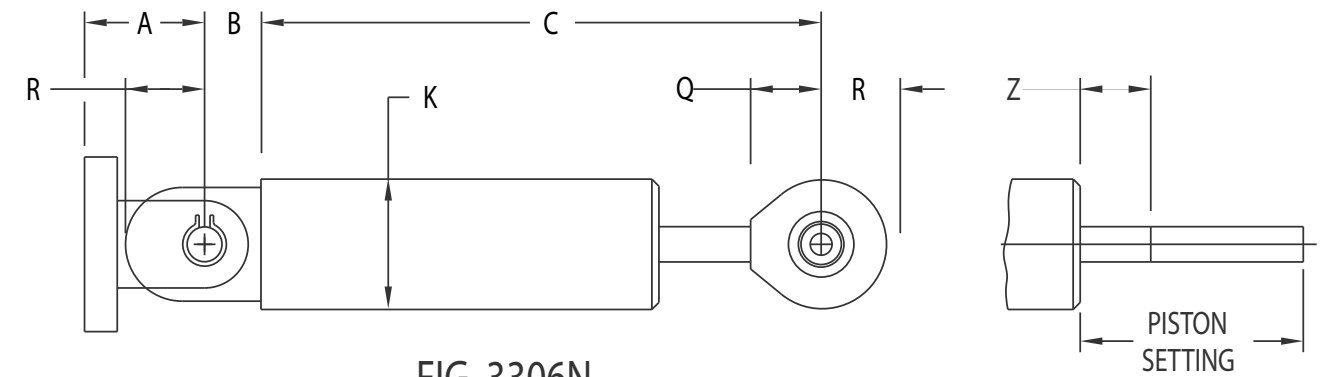

FIG. 3306N

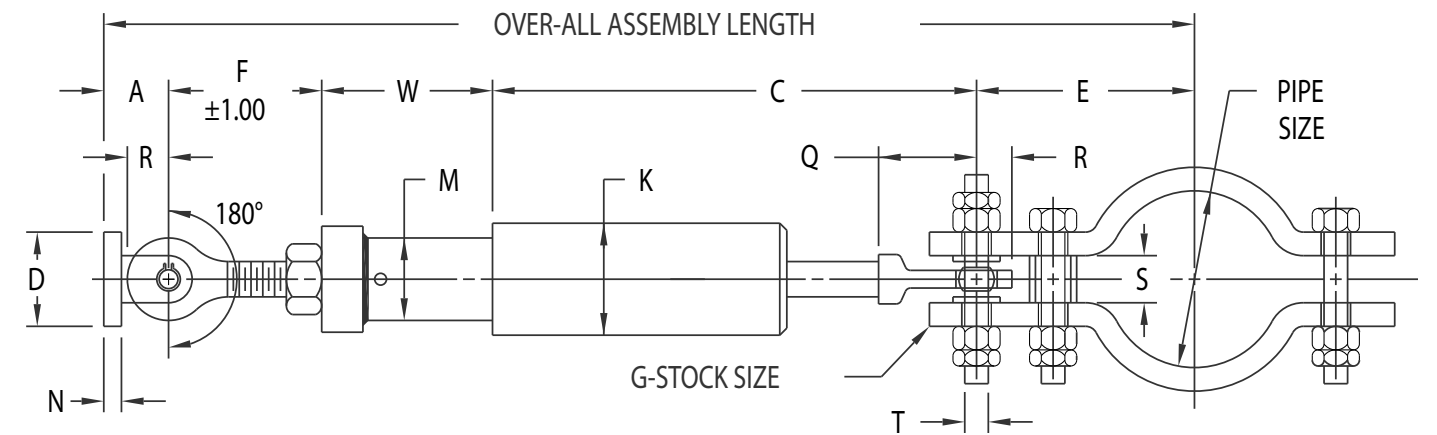

FIG. 3307N

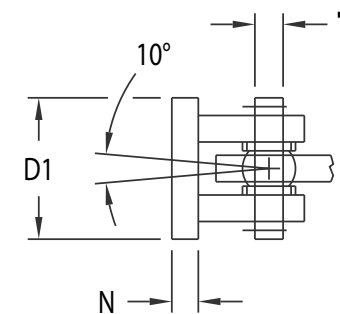

Fig. 3306N

Fig. 3307N

Nuclear Safety  
Related Applications

DIMENSIONAL DATA (INCHES)											
Snubber Size	Stroke	A	B	C			D	D1	F	K Dia	M Dia
				Min	Mid	Max					
¼	*4.00	1.00	1.19	9.00	11.00	13.00	2.88	1.25	2.94	2.25	1.31
½	*2.50			7.50	8.75	10.00					
	1	*4.00	1.62	1.56	11.00	13.00	15.00	4.00	1.75	3.00	2.38
8.00		15.50			19.50	23.50					
3	*5.00	2.12	2.62	14.00	16.50	19.00	5.00	3.62	4.50	4.62	2.38
	10.00			20.00	25.00	30.00					
10	*6.00	3.00	4.06	16.10	19.10	22.10	7.00	4.00	5.12	5.75	2.88
	12.00			23.10	29.10	35.10					
35	*6.00	4.62	3.00	24.00	27.00	30.00	9.75	6.50	7.75	6.00	4.50
100	*600	7.25	3.80	29.00	32.00	35.00	14.00	8.75	8.31	10.00	5.56

Snubber Size	Stroke	F	Q (Ref)	R Max	S	T Dia	W		Z	Maximum Pin To Pin
							Min	Max		
¼	4.00	.25	1.19	.63	.63	.374 .372	3.50	45.56	.19	61.50
½	2.50						3.50	48.56		
	1	4.00	.375	2.00	1.00	1.00	.499 .497	3.81	43.50	.12
8.00		N/A						N/A		
3	5.00	.50	2.12	1.38	1.38	.749 .747	4.44	37.50	1.25	61.00
	10.00						N/A	N/A		
10	6.00	1.00	2.00	1.62	1.38	.999 .997	5.19	44.50	2.10	71.72
	12.00						N/A	N/A		
35	6.00	1.25	3.00	2.79	2.00	1.499 1.497	5.25	79.75	1.48	117.50
100	6.00	2.25	3.80	3.44	N/A	2.499 2.497	6.50	74.18	3.38	117.50

To order Fig. 3306N specify: Size (nominal kips), Stroke, Fig. No., Cold Setting Hot Setting, less pivot mount if applicable and load.

To order Fig. 3307N specify: Size (nominal kips), Stroke, Fig. No., W Dimension Cold Setting, Hot Setting and Load.

Note: Make sure that all normal movement of equipment will be accommodated without the suppressor entering the last ¼" (preferably ½") of stroke at either end.

Note: Loads are double acting.

\* These sizes may be ordered for use with existing hardware.

*Pipe Size	E-TAKE OUT					G-STOCK SIZE				
	Snubber Size					Snubber Size				
	¼ & ½	1	3	10	35	¼ & ½	1	3	10	35
¾	2 7/16	-	-	-	-	¾ x 1	-	-	-	-
1	2 5/16	-	-	-	-	¾ x 1	-	-	-	-
1 ¼	2 11/16	-	-	-	-	¾ x 1	-	-	-	-
1 ½	4 1/8	-	-	-	-	¼ x 1 ¼	-	-	-	-
2	5 3/8	-	-	-	-	¼ x 1 ¼	-	-	-	-
2 ½	5 3/8	7	7	7	-	¼ x 1 ¼	¾ x 1 ¾	½ x 2 ½	¾ x 2 ½	-
3	5 15/16	7	7	8 1/8	-	¼ x 1 ¼	¾ x 1 ¾	½ x 2 ½	¾ x 2 ½	-
3 ½	6 3/16	7	7	8 3/8	-	¼ x 1 ¼	¾ x 1 ¾	½ x 2 ½	¾ x 2 ½	-
4	6 1/2	7 ¼	7 ¼	8 3/8	-	5/16 x 2	½ x 1 ½	¾ x 2 ½	¾ x 2 ½	-
5	7 ¾	7 ¾	7 ¾	9 1/8	-	5/16 x 2	½ x 1 ½	¾ x 2 ½	¾ x 3	-
6	8 3/8	8 3/8	8 3/8	10	-	5/16 x 2	½ x 2	¾ x 3	¾ x 4	-
8	9 3/8	9 3/8	9 3/8	11 ¼	12 3/8	5/16 x 2	½ x 2 ½	¾ x 3	¾ x 5	1 x 7
10	10 ½	10 ½	10 ½	12 ¾	14 ¼	5/16 x 2	¾ x 2 ½	¾ x 4	¾ x 6	1 ¼ x 6
12	-	11 3/8	11 3/8	13 3/8	15 3/8	-	¾ x 2 ½	¾ x 5	1 x 5	1 ¼ x 6
14	-	12 3/8	12 3/8	14 ½	16	-	¾ x 2 ½	¾ x 5	1 x 5	1 ¼ x 7
16	-	13 3/8	13 3/8	15 ¼	17 1/8	-	¾ x 3	¾ x 5	1 x 5	1 ¼ x 8
18	-	14 3/8	14 3/8	16 3/8	18 ¼	-	¾ x 3	¾ x 5	1 x 6	1 ¼ x 9
20	-	15 3/8	15 3/8	17 ¾	19 ¼	-	¾ x 3	¾ x 5	1 x 7	1 ½ x 8
24	-	18 3/8	18 3/8	19 7/8	21 ¾	-	¾ x 4	¾ x 5	1 x 7	1 ½ x 9
30	-	21 ¼	21 ¼	23	25	-	¾ x 4	¾ x 6	1 x 7	1 ½ x 10
36	-	24	24	26 ½	28 1/8	-	¾ x 5	¾ x 7	1 x 7	1 ½ x 10

\* Intermediate sizes between 20 and 36 are available and will have the take out and stock of the next larger size.

## Anvil's Tapered Pin: Fast, Easy Removal

The unique design of Anvil's Fig. 312 Tapered Pin facilitates easy removal at time of rebuild or testing, particularly in corrosive environments. The tapered pin, available in 3/8" through 2 1/2" nominal diameters, consists of a tapered center pin which is inserted into a slotted sleeve. The sleeve expands to the nominal diameter when the hex nut is tightened. Larger sizes are available on request.

Removing the pin is accomplished by removing the cotter pin and loosening the slotted hex nut and washer or loosening jam nuts. A slight tap with a hammer on the nut end is generally sufficient to loosen the pin inside the sleeve and remove the entire assembly from the bracket.

This design sharply reduces the time necessary to remove a badly corroded conventional pin and may also eliminate damage to the bushing and bracket assembly, particularly if the pin and bracket are corroded. In nuclear stations, this feature complements ALARA standards by reducing personnel exposure time.

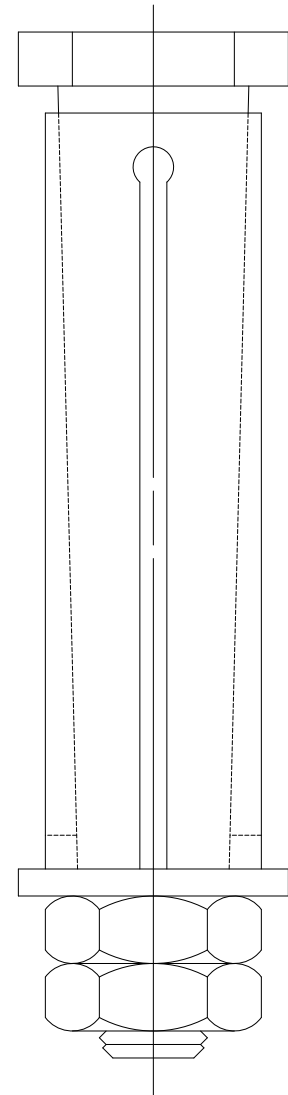

Dimensional Data					
Pin Size (Nominal)	S (Max.)	B (Max.)	Compatible With Fig.		
			200N / 201N	211N / 222N / 640N	3306N / 3307N
3/8	.62	1.25	—	A	1/4 & 1/2
1/2	1.00	1.75	—	—	1
3/4	1.38	2.88	1 1/2	B & C	3
1	1.38	3.38	2 1/2	1 & 2	10
1 1/4	1.69	3.19	3 1/4	3 & 4	—
1 1/2	2.00	5.50	4	5	35
1 3/4	2.38	4.88	5	6	—
2	2.75	5.75	6	7	—
2 1/2	3.38	6.88	8	8	100

\* Either available w/2 Jam Nuts or Castle Nut & Cotter Pin.

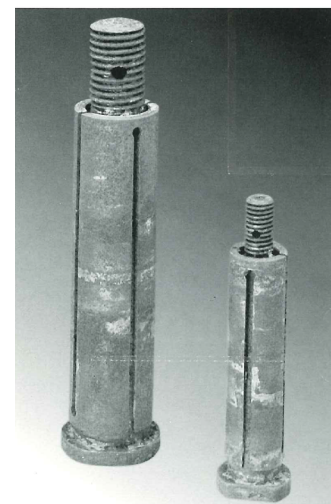

### Salt Spray Test Data

The Fig. 312 Tapered Pin was tested for corrosion resistance in a 160 hour salt spray test. The pins were placed in the salt spray test chamber with standard snubber pins.

After the 160 hour test, the 312 Tapered Pin could be easily removed from its rear bracket; the standard pin either galled or caused damage to the rear bracket when removed.

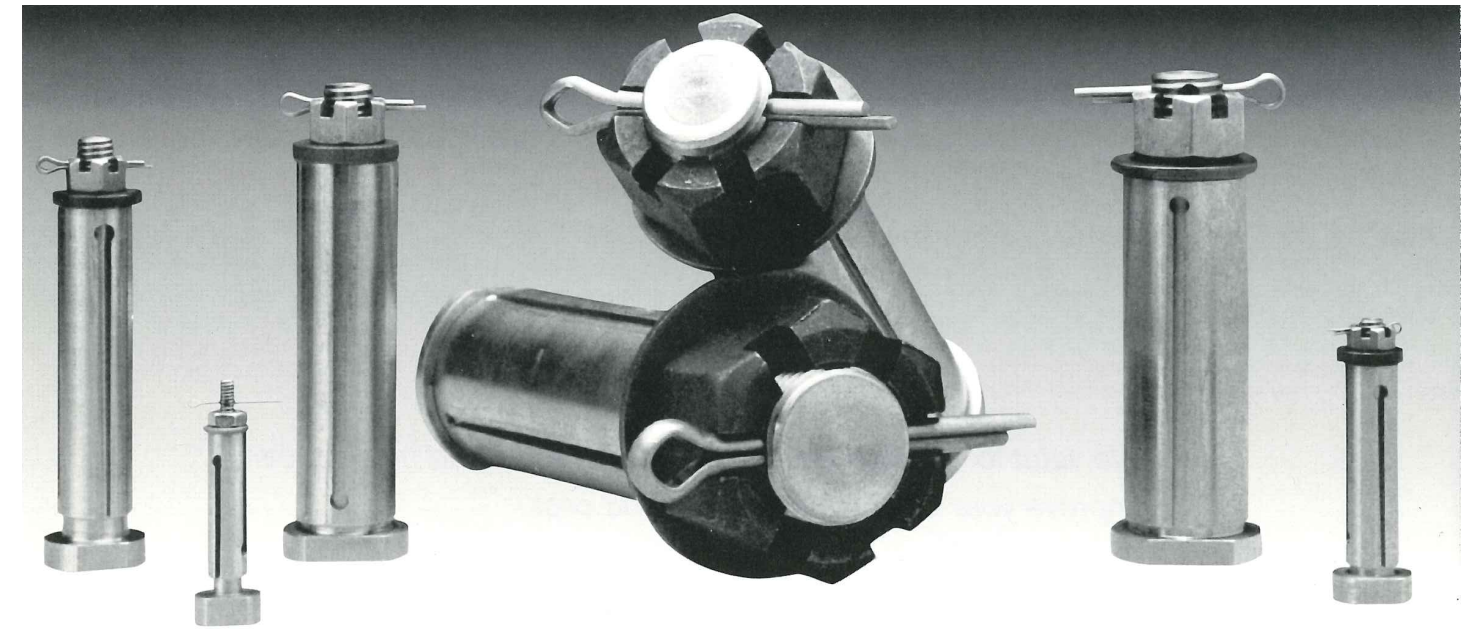

### How to Size:

Select size consistent with pin diameter for size Fig. 200/201 or Fig. 3306/3307. May be used with Fig. 211, 222, and 640.

Material Data		
Item	Material Specification	Item Type
Pin	SA-193 Gr. B7	Primary
Sleeve	SA-193 Gr. B7, ASTM A-519 Gr. 1018 or 1026 C.W.*; ASTM A-513 Gr. 1026 C.W.*	Primary
Cotter Pin	Steel – Exempt per NF212 1b.	Secondary
Washer	Steel – Exempt per NF212 1b.	Secondary
Nut	ASTM A-563 Gr. A*	Secondary

\* Code Case N-249 Nut. A-194 Gr. 24. Stainless steel available upon request.

### Ordering:

Specify figure number, nominal pin size, and name.

Nominal Pin Diameter	Max Recom Load* (lbs.)	L	For Use With Fig.	
			200 / 201	3306 / 3307
3/8	650	1 1/4	—	1/4 & 1/2
1/2	1,500	2 3/8	—	1
3/4	6,000	3 7/8	1 1/2	3
1	15,000	4 3/8	2 1/2	10
1 1/4	20,700	4 3/4	3 1/4	—
1 1/2	50,000	7 1/4	4	35
1 3/4	45,500	7	5	—
2	68,200	8 1/4	6	—
2 1/2	120,000	9 3/8	8	100

LCD's available for nuclear applications. Design level C & D loads available on request. NOTE: May also be used with figure numbers 211, 222, and 640.

## Anvil's Snubbers:

### Impeccable Performance for Critical Applications

## Rebuild Services:

In addition to providing the highest quality and most reliable hydraulic snubbers, we also provide inspection and rebuild services. Hydraulic snubbers require periodic maintenance (such as seal replacements) and Anvil can refurbish our existing models, as well as Grinnell and ITT Grinnell models after 1974. Rebuild and refurbishment includes replacement of all elastomers, hydraulic fluid, a functional test with test report, and any other parts found to be damaged.

We can also ship seal kits for our Fig. 200 series so users with a test bench and purge rig can rebuild their own on site.

Please inquire for rebuilds on the Fig. 3306.

For rebuild inquiries or seal kits please contact: 855-EPS-PIPE.

## On-Site Technical Service:

Anvil also offers on-site technical service and assistance for snubber programs. Whether it is field walkdowns, rebuild supervision or technical advice, our field service representatives are available within 24 hours to help you out of your outage jams and get your snubbers operable and your plants up and running. We can also ship stocked material within 24 hours, and can get rebuilds turned around same day if required.

For on-site technical service or questions, please contact our 24 Hour Technical Hotline at: 401-533-6896.

NUCLEAR RENEWABLE ENERGY COAL & NATURAL GAS MARINE  
DEFENSE PETRO-CHEMICAL NUCLEAR RENEWABLE ENERGY COA  
& NATURAL GAS MARINE DEFENSE PETRO-CHEMICAL NUCLEA  
RENEWABLE ENERGY COAL & NATURAL GAS MARINE DEFENS  
PETRO-CHEMICAL NUCLEAR RENEWABLE ENERGY COAL & NA  
URAL GAS MARINE DEFENSE PETRO-CHEMICAL NUCLEAR RENEW  
ABLE ENERGY COAL & NATURAL GAS MARINE DEFENSE PETRO



### **About ASC Engineered Solutions**

ASC Engineered Solutions is defined by quality—in its products, services and support. With more than 1,400 employees, the company’s portfolio of precision-engineered piping support, valves and connections provides products to more than 4,000 customers across industries, such as mechanical, industrial, fire protection, oil and gas, and commercial and residential construction. Its portfolio of leading brands includes ABZ Valve®, AFCON®, Anvil®, Anvil EPS, Anvil Services, Basic-PSA, Beck®, Catawissa, Cooplet®, FlexHead®, FPPI®, Gruvlok®, J.B. Smith, Merit®, North Alabama Pipe, Quadrant®, SCI®, Sharpe®, SlideLOK®, SPF® and SprinkFLEX®. With headquarters in Commerce, CA, and Exeter, NH, ASC also has ISO 9001:2015 certified production facilities in PA, TN, IL, TX, AL, LA, KS, and RI.



[asc-es.com](http://asc-es.com)

Building connections that last™

